

FIERCE VEHICLE FIRE SUPPRESSION

KODIAK 
FIERCE VEHICLE FIRE PROTECTION



Quality is Behind the Diamond[®]



QUALITY WITHOUT COMPROMISE & EXPERIENCED INNOVATION

 The best forestry operations are uncompromising when it comes to the quality and reliability of their vehicles. At Amerex, we believe the same should be true when it comes to protecting those investments from debilitating fires and loss of production. With the experience of over 200,000 vehicle fire suppression systems sold, the Amerex vehicle fire suppression team has developed the most innovative fire suppression systems in the industry. **The KODIAK Fire Suppression Systems provide Fast and Fierce Fire Protection.**



Engineered system rigorously tested and designed to be tailored for any situation—**that's quality behind the diamond.**

All Amerex Fire Extinguishers comply with the recommendations of the **National Fire Protection Association** and are tested to **FM Global** and **UL 1254 Standards**.

**DESIGNED AND
MANUFACTURED
IN THE USA**



Note: The illustrations shown within are conceptual only and not intended for system design. A complete hazard analysis and risk assessment should be performed on the vehicle to determine the most probable ignition sources; along with the fire characteristics and quantity of the various fuels exposed to those ignition sources. Final placement of the fire suppression components should be based on the hazard analysis and in coordination with the end user.

The **AMEREX KODIAK BENEFITS** **STORED PRESSURE AGENT CYLINDERS**

Vehicles are different, and so are the Protection Agent Options

All vehicle hazards are not the same, so we offer two different suppression agent options to protect your vehicle.

- **Dry Agent Systems** - Provides the fastest fire knockdown available and can get into those hard-to-reach areas where fire may hide.
- **Amerex Dry-ICS Systems** - Combines the strengths of both agents and provides the best possible fire protection option by providing rapid fire knockdown with dry agent and the cooling effects of the ICS liquid agent system.

Dry Agent Cylinders



ICS Liquid Agent Cylinders



WHY STORED PRESSURE?

- Prevents moisture from entering the cylinder and contamination of the fire suppression agent
- Agent is fluidized and ready to go when needed; no need for delays while the cylinder is being pressurized from an outside source
- Maintenance personnel can verify readiness at a glance with the cylinder's pressure gauge
- Stored pressure cylinders can be fitted with a pressure switch which detects a low pressure condition and notifies the operator via the control panel



The **AMEREX BENEFITS** CONTROL PANEL OPTIONS



FEATURES OF THE **SAFETYNET** PANEL

- Full network ability to add additional detection and releasing zones
- 4000 event log—time and date stamped, down-loadable log for easy troubleshooting and incident investigation
- Automatic Maintenance Testing (AMT) mode to significantly reduce maintenance time
- Supports natural gas detection and infrared flame detectors for combination fire and natural gas detection systems
- 24-hour battery backup protection



FEATURES OF THE **17 SERIES** PANEL

- Two detection zones and one releasing zone
- 24-hour battery backup protection
- Diagnostic flash code for easy troubleshooting
- Programmable discharge and alarm relays



DID YOU KNOW?

Event logs can be downloaded and provided to the vehicle owner to verify testing has been completed and kept as part of that unit's permanent record.



APPROVED
Approval Standard 5970



The **AMEREX BENEFITS** FIRE DETECTION OPTIONS



LINEAR HEAT DETECTION cables have long been the industry standard and provide a continuous heat detection cable run inside the hazard area. The Amerex Benefit has amped up the traditional cable with a more robust abrasion resistant outer jacket and factory installed connectors for reliability and ease of service. The cable is also available with a stainless steel wire protective covering for extreme environments.

SPOT HEAT DETECTORS are available in three different preset temperature settings for flexibility and provide rapid heat detection and system activation. Spot Heat Detectors have factory installed connectors for reliability and ease of installation and service.

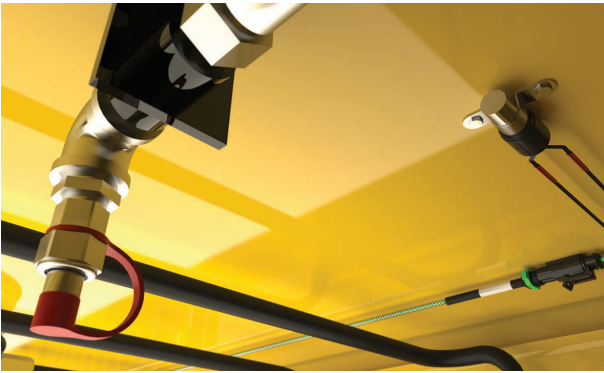

FAST FACT

Multiple types of detectors can be used on the same vehicle to provide faster response in high risk areas.

The **AMEREX BENEFITS** ICS LIQUID

AMEREX ICS SUPPRESSION SYSTEM

- Amerex ICS System is an FM Approved, pre-engineered fire suppression and cooling system designed specifically for protection of vehicles
- Each system uses vertical or horizontal stored pressure agent cylinders discharging ICS agent to predetermined nozzle flow rates
- The ICS system works by blanketing liquid fuel surfaces preventing oxygen from combining with ignition sources and fuel
- Each system provides cooling of heated surfaces to reduce the chances of a fire re-ignition
- Each system can operate within temperature ranges from -30F to 120F (-34C to 49C)

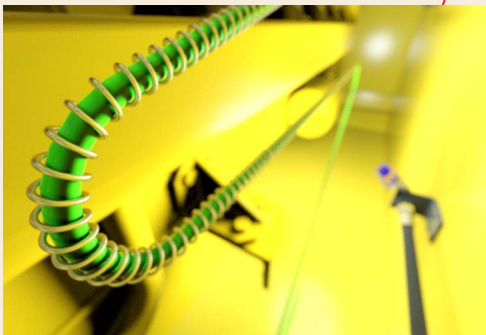
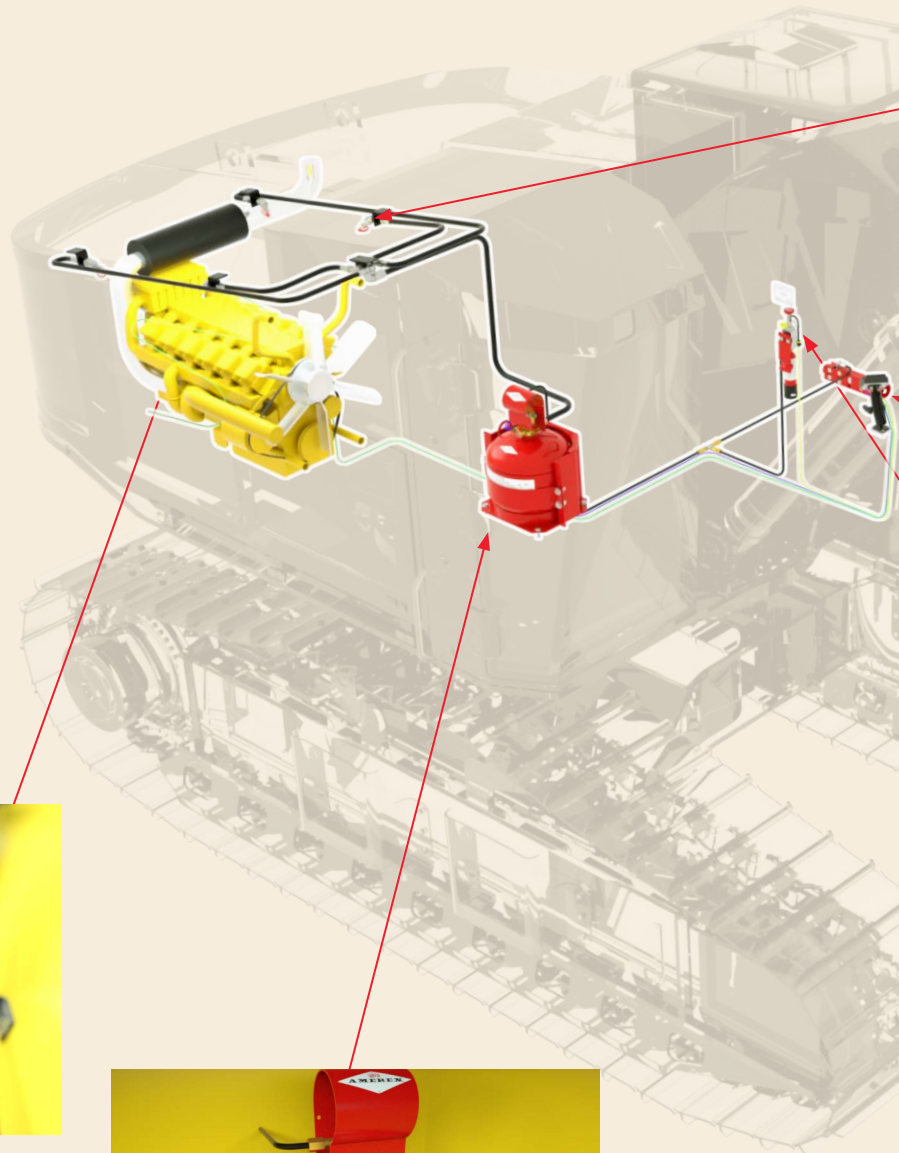

Detection Network



Agent Cylinders



FAST FACT

ICS liquid agent significantly reduces clean up time after a discharge by containing the agent to the hazard area.

AGENT SYSTEMS



ICS Nozzles



17 Series Panel



Z Series Extinguisher

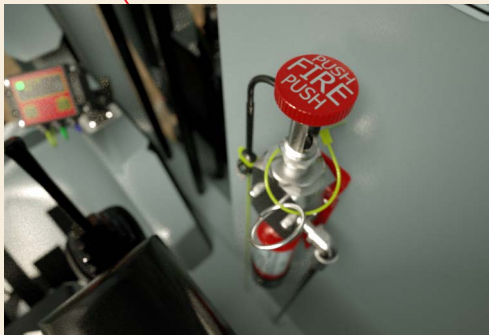

Manual Actuator



DID YOU KNOW?

The Amerex ICS system is also highly effective on cooling and wetting ordinary combustible Class A materials.



APPROVED
Approval Standard 5970

The **AMEREX BENEFITS** DRY-ICS DUAL

AMEREX DRY-ICS DUAL AGENT SUPPRESSION SYSTEM

- Amerex Dry-ICS System provides the best possible fire protection option by combining the rapid knockdown power of dry agent with the cooling effect of ICS liquid agent
- The dual agent is designed for simultaneous discharge or with a time delay between Dry and ICS release for an extended discharge for larger vehicles
- The Dry-ICS system meets the dual agent requirement of NFPA 122 12.3.6.1.1 for hydraulic/diesel excavators with hydraulic systems larger than 150 gallons

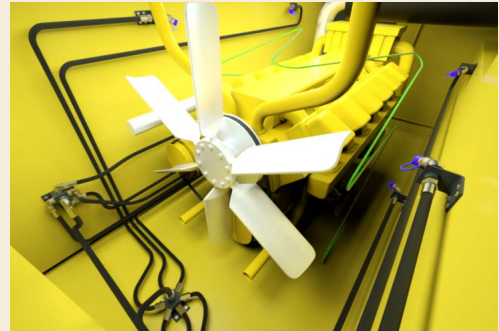

Engine Compartment

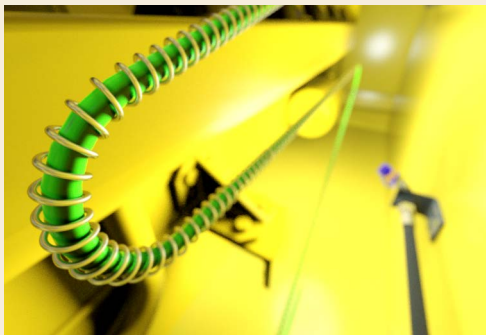

Detection Network



FAST FACT

Amerex control panels have programmable discharge delays from 0-15 seconds in 5 second increments.



Manual Actuator

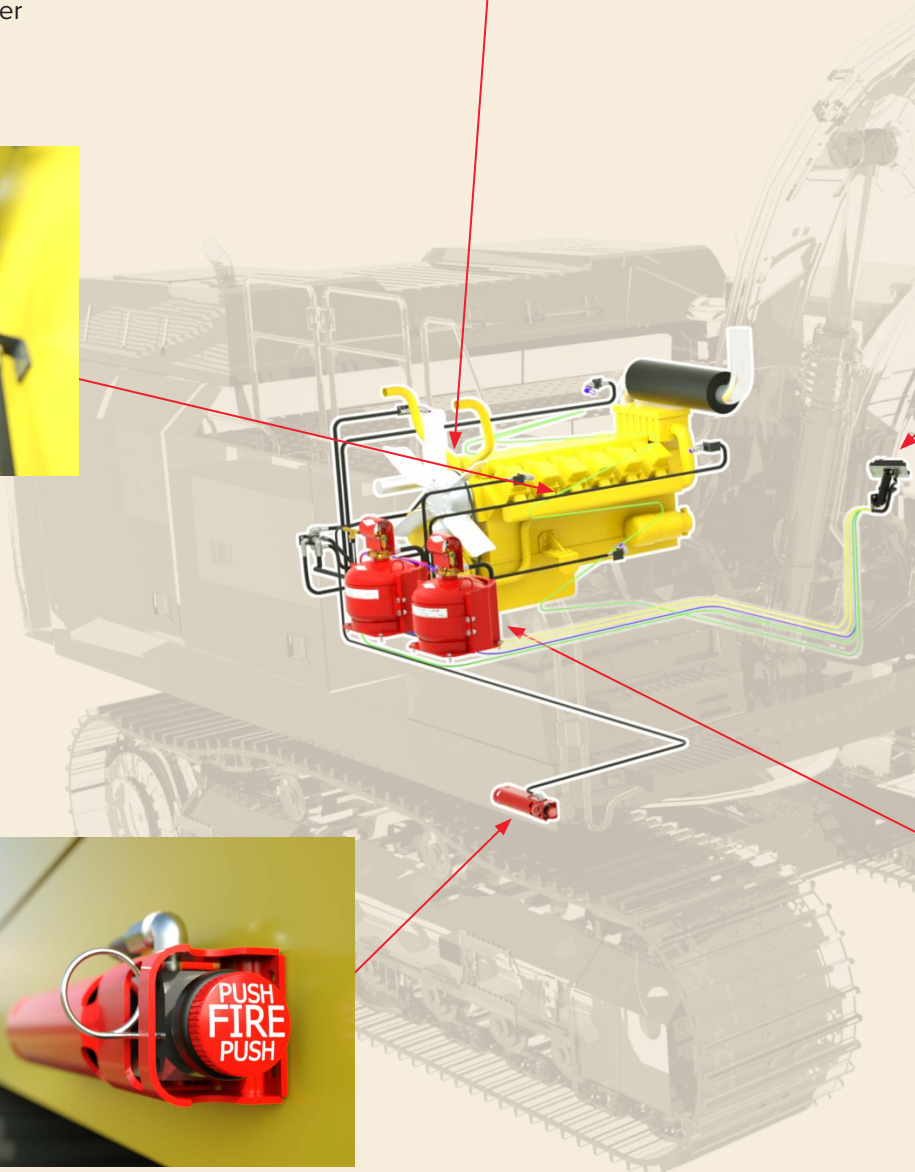

AGENT SYSTEMS

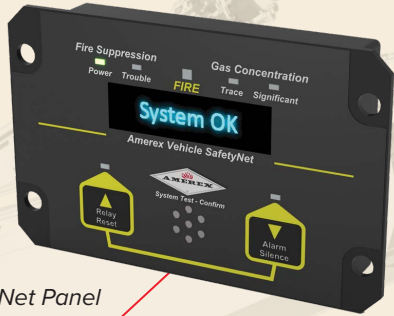

SafetyNet Panel



DID YOU KNOW?

Fires on forestry equipment with large volumes of hydraulics and diesel fuels can reignite after a fire is suppressed if the flammable fuel is not shut off, or the ignition sources aren't cooled.



Z Series Extinguisher



Cylinders



APPROVED
Approval Standard 5970

The **AMEREX BENEFITS** DRY CHEMICAL

AMEREX DRY CHEMICAL SYSTEMS

- Amerex dry chemical systems have long been the industry standard for fire suppression of vehicles
- Dry chemical is so effective because of its ability to flow around obstructions to get to the hidden areas where fires start. Water based agents cannot get to these areas allowing the fire to grow and spread
- Dry chemical provides the fastest fire knockdown of any fire suppression agent on the market—reducing the amount of fire damage
- Each system uses vertical or horizontal stored pressure agent cylinders discharging dry chemical at predetermined nozzle flow rates
- Dry chemical cylinders are listed to operate within temperature ranges from -65F to 150F (-54C to 66C)



APPROVED
Approval Standard 5970



DID YOU KNOW?

Third party independent testing has shown that “water mist” type systems are not effective on hidden fires and that Dry Chemical is highly effective on hidden fires.

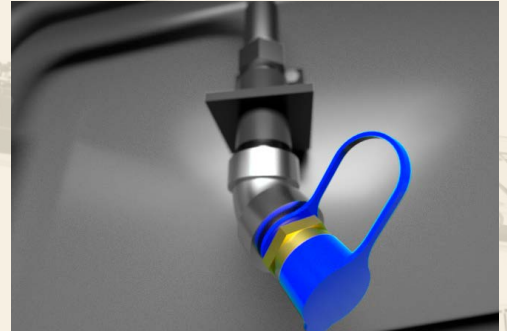

Dry Nozzles

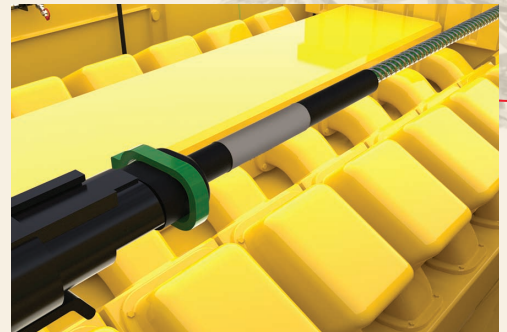

Detection Network

SYSTEMS

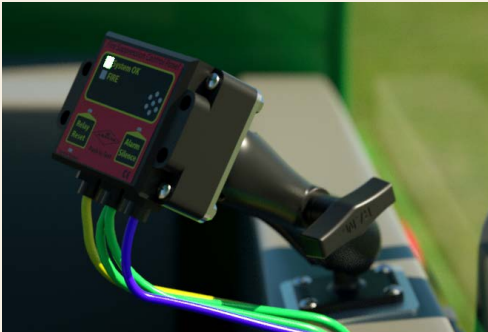

17 Series Panel

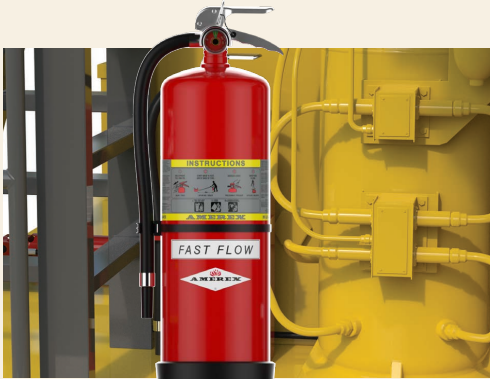

Z Series Extinguisher



Manual Actuator



Agent Cylinder

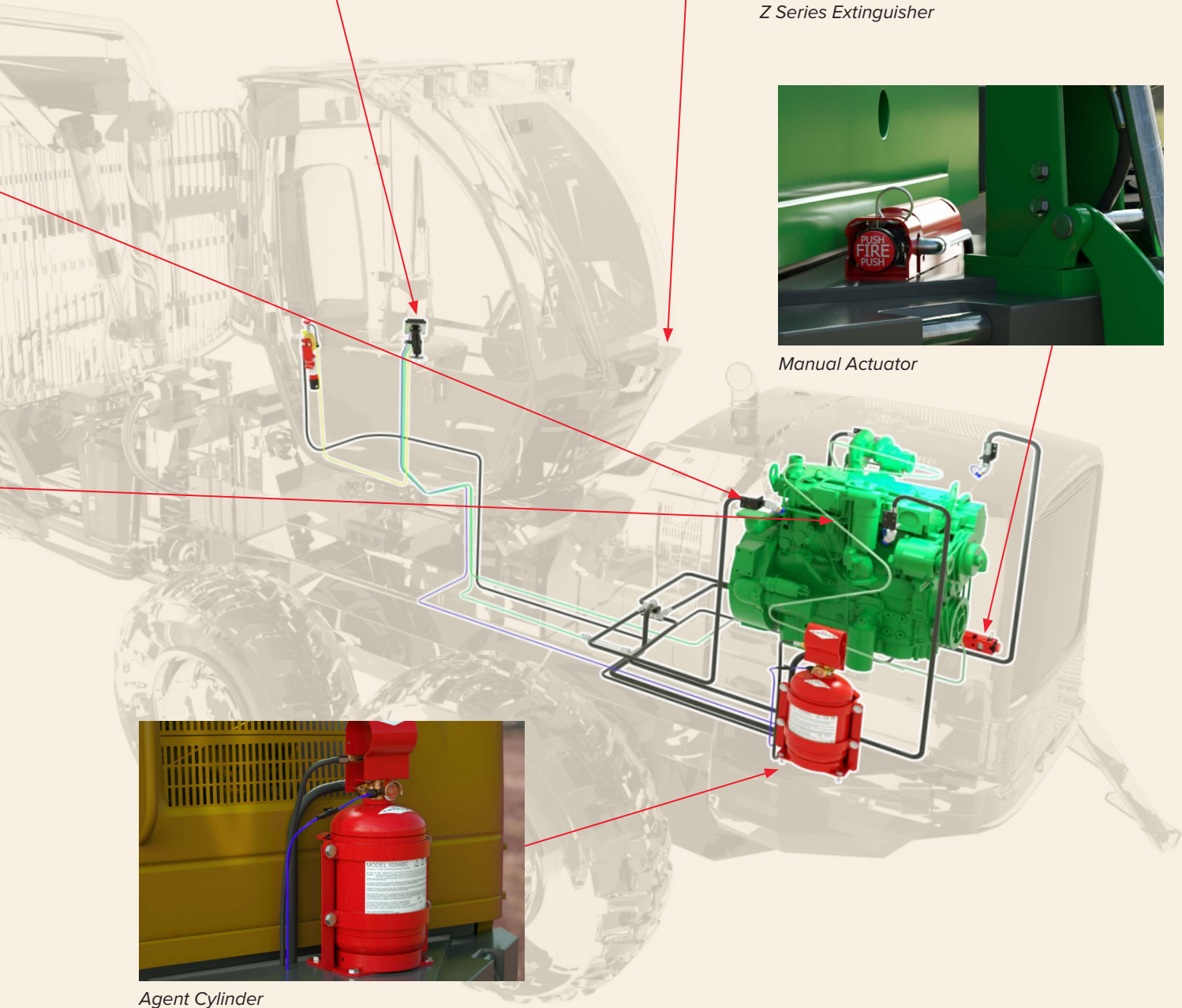

why AMEREX?

QUALITY

Amerex didn't become a global market leader overnight. Our business has grown year after year based on our products' reputation for performance and durability in even the most rugged environments.

INNOVATION

Because Amerex is independently owned and forward thinking, we are continuously innovating and investing for the benefit of our customers and those they serve.

SERVICE

Amerex was founded on a mutual appreciation for premium quality in products and customer service and the importance of interpersonal relations.



Quality is Behind the Diamond®

7595 Gadsden Hwy. P.O. Box 81 Trussville, AL 35173 Ph: (205) 655-3271
www.amerex-fire.com webstore.amerex-fire.com customer.service@amerex-fire.com intl.sales@amerex-fire.com

© 2026 Amerex Corporation internationally recognized ISO 9001 and ISO 14001 registered firm



Amerex Fire Protection



Amerex Corporation



@Amerex Corporation



@Amerex Corp



@Amerex Corporation



Amerex